

L8542929
07/2011 Rev.1

BENINCA®

APRICANCELLO ELETTROMECCANICO
ELECTROMECHANICAL GATE OPENER
ELEKTROMECHANISCHE AUTOMATION FÜR SCHIEBEGITTER
AUTOMATISATION ÉLECTROMÉCANIQUE POUR GRILLES
ABRECANCELA ELECTROMECHANICO
ELEKTROMECHANICZNY OTWIERACZ BRAM

DU.IT24NVE

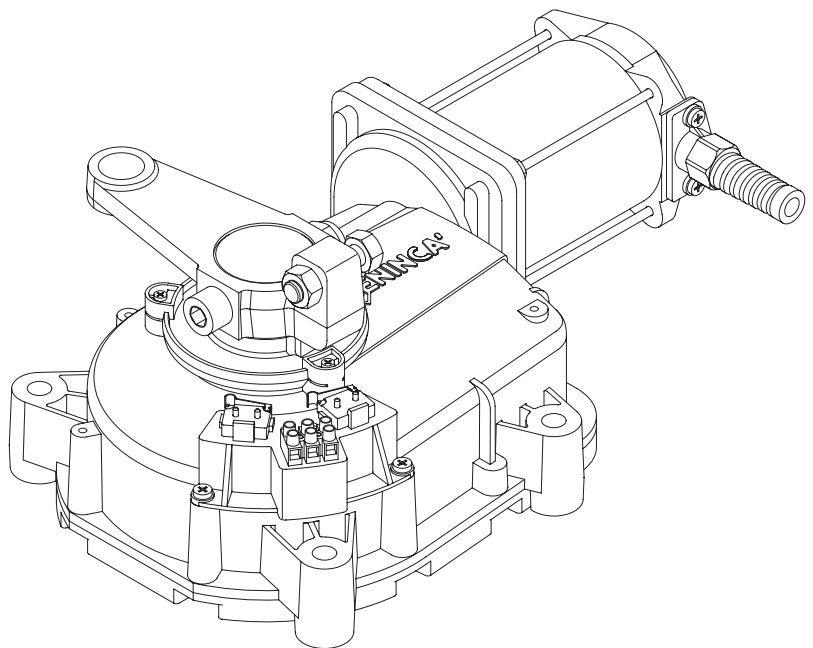

Manual istruzioni e catalogo ricambi

Operating instructions and spare parts catalogue

Betriebsanleitung und Ersatzteilliste

Livret d'instructions et catalogue des pieces de rechange

Manual de instrucciones y catálogo de recambios

Książeczka z instrukcjami i katalog części wymiennych



UNIONE NAZIONALE COSTRUTTORI
AUTOMATISMI PER CANCELLI, PORTE
SERRANDE ED AFFINI

Dichiarazione CE di conformità per macchine
(Direttiva 89/392 CE, Allegato II, parte B)
Divieto di messa in servizio

Fabbricante: **Automatismi Benincà SpA**
Indirizzo: Via Capitello, 45 - 36066 Sandrigo (VI) - Italia

Dichiara che: l'automazione per cancelli a battente modello **DU.IT24NVE**.

- è costruito per essere incorporato in una macchina o per essere assemblato con altri macchinari per costituire una macchina considerata dalla Direttiva 89/392 CE, come modificata;
- non è dunque conforme in tutti i punti alle disposizioni di questa Direttiva;
- è conforme alle condizioni delle seguenti altre Direttive CE:
Direttiva compatibilità elettromagnetica 89/336/CEE, 93/68/CEE.

e che:

- sono state applicate le seguenti (parti/clausole di) norme armonizzate:
EN 55022, EN 61000-3-2, EN 61000-3-3, EN 50082-1.

e inoltre dichiara che non è consentito mettere in servizio il macchinario fino a che la macchina in cui sarà incorporato o di cui diverrà componente sia stata identificata e ne sia stata dichiarata la conformità alle condizioni della Direttiva 89/392 CE e alla legislazione nazionale che la traspone, vale a dire fino a che il macchinario di cui alla presente dichiarazione non formi un complesso unico con la macchina finale.

Benincà Luigi, Responsabile legale.
Sandrigo, 10/01/2005.

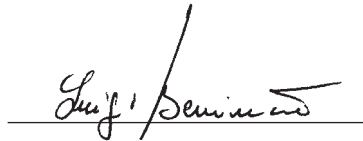

Declaration by the manufacturer
(Directive 89/392/EEC, Art. 4.2 and Annex II, sub B)
Divieto di messa in servizio

Manufacturer: **Automatismi Benincà SpA**
Address: Via Capitello, 45 - 36066 Sandrigo (VI) - Italia

Herewith declares that: the operator for hinged gates model **DU.IT24NVE**.

- is intended to be incorporated into machinery or to be assembled with other machinery to constitute machinery covered by Directive 89/392 EEC, as amended;
- does therefore not in every respect comply with the provisions of this Directive;
- does comply with the provisions of the following other EEC Directives:
Direttiva compatibilità elettromagnetica 89/336/CEE, 93/68/CEE.

and that:

- the following (parts/clauses of) harmonized standards have been applied:
EN 55022, EN 61000-3-2, EN 61000-3-3, EN 50082-1.

and furthermore declares that it is not allowed to put the machinery into service until the machinery into which it is to be incorporated or of which it is to be a component has been found and declared to be in conformity with the provisions of Directive 89/392/EEC and with national implementing legislation, i.e. as a whole, including the machinery referred to in this declaration.

Benincà Luigi, Responsabile legale.
Sandrigo, 10/01/2005.

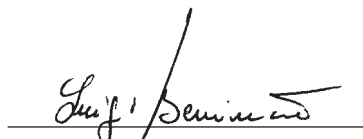

| Dati tecnici | Technical data | Technische Daten | Donnees technique | Datos técnicos | Dane techniczne | DU.IT24NVE |
|------------------------|------------------------------|------------------------------|------------------------------|--------------------------|-----------------------------|----------------------|
| Alimentazione | Power supply | <i>Speisung</i> | Alimentation | Alimentación | Zasilanie | 24 Vdc |
| Corrente assorbita | Absorbed current | <i>Strom-Verbrauch</i> | Courant absorbé | Corriente absorbida | Pobór prądu | 11 A |
| Coppia | Torque | <i>Drehmoment</i> | Couple | Empuje | Moment obrotowy | 280 Nm |
| Peso max anta | Max. wing weight | <i>Max. Flügelwicht</i> | Poids max. porte | Peso máx. de hoja | Max ciężar skrzydła bramy | 300 kg |
| Tempo per apertura 90° | 90° opening time | <i>90° Öffnungszeit</i> | Temps ouverture 90° | Tiempo para abrir 90° | Czas na wykon. przes.do 90° | ~15 s |
| Lunghezza max. anta | Max. wing width | <i>Max. Flügelänge</i> | Longueur max. porte | Longitud máx. hoja | Max długość skrzydła bramy | 3,5 m |
| Temper. funzionamento | Operating temperature | <i>Laufzeit</i> | Température de fonct. | Temperatura funcionam. | Temper. podczas pracy | -20°C/+50°C |
| Intermittenza lavoro | Jogging | <i>Betriebsintervall</i> | Intermittence travail | Intermitencia de trabajo | Cykliczność pracy | * |
| Grado di protezione | Protection degree | <i>Schutzgrad</i> | Degré de protection | Grado de protección | Stopień ochrony | IP67 |
| Rumorosità | Noise level | <i>Geräuschentwicklung</i> | Bruit | Ruido | Hałaśliwość | <70dB (a) |
| Lubrificazione | Lubrication | <i>Schmierung</i> | Lubrification | Lubrificación | Smarowanie | Grasso GR LP1 |
| Peso motoriduttore | Gearde motor weight | <i>Getriebemotor Gewicht</i> | Poids motoréducteur | Peso motor | Ciężar silownika | 10,0 kg |

* *Usa intensivo - Intensive use - Intensive Nutzung - Usage intensif - Uso intensivo - Użytkowanie intensywne*

Dimensioni d'ingombro
Overall dimensions
Abmessungen
Dimensions d'encombrement
Dimensiones exteriores
Wymiary gabarytowe

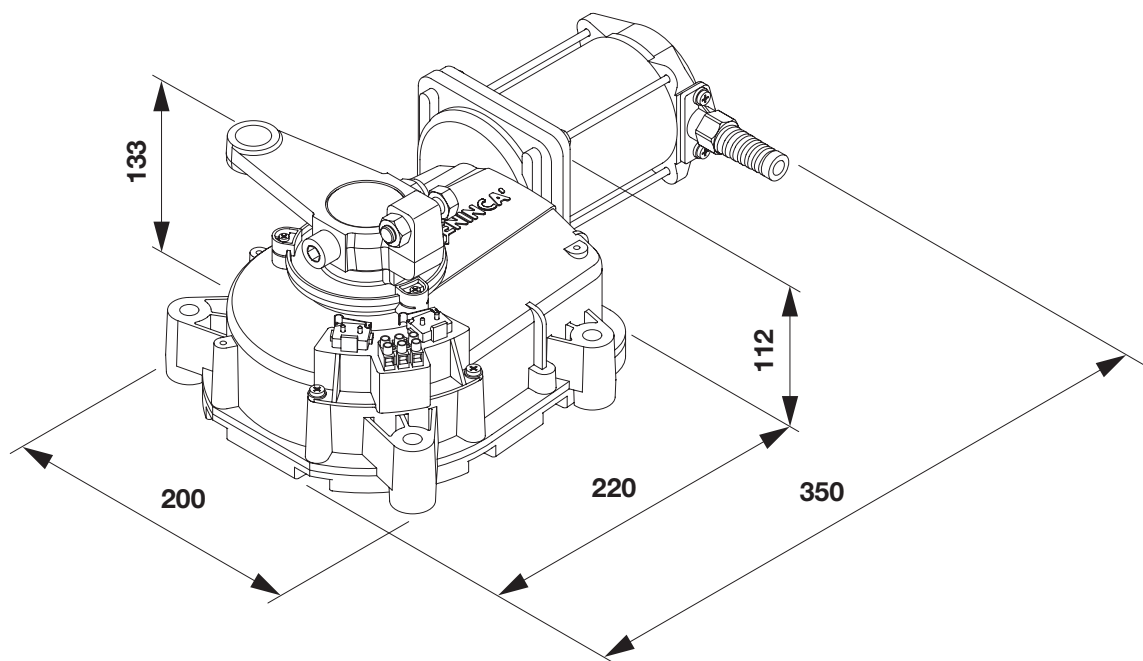

Fig.1

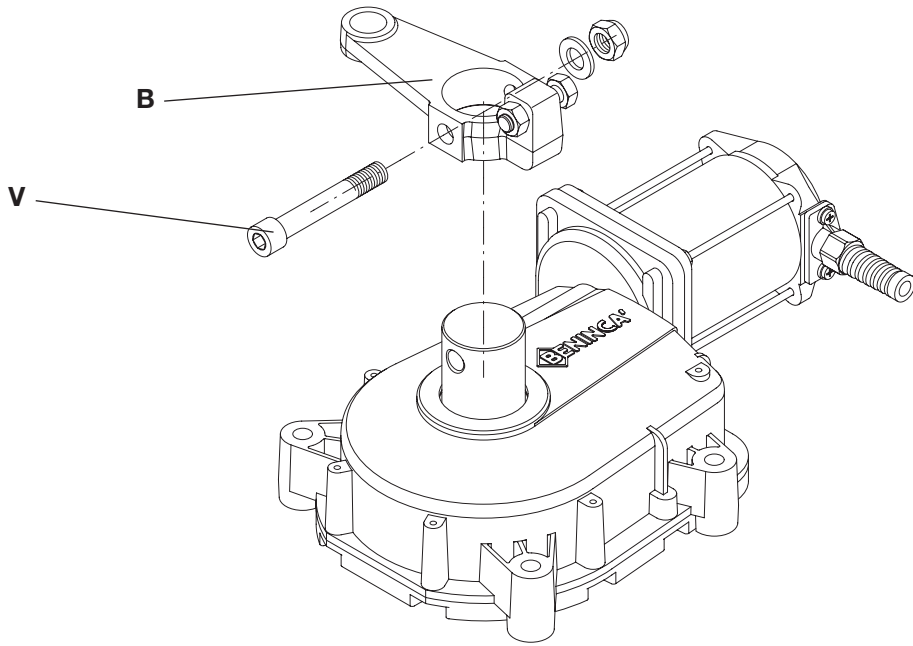

Fig.2

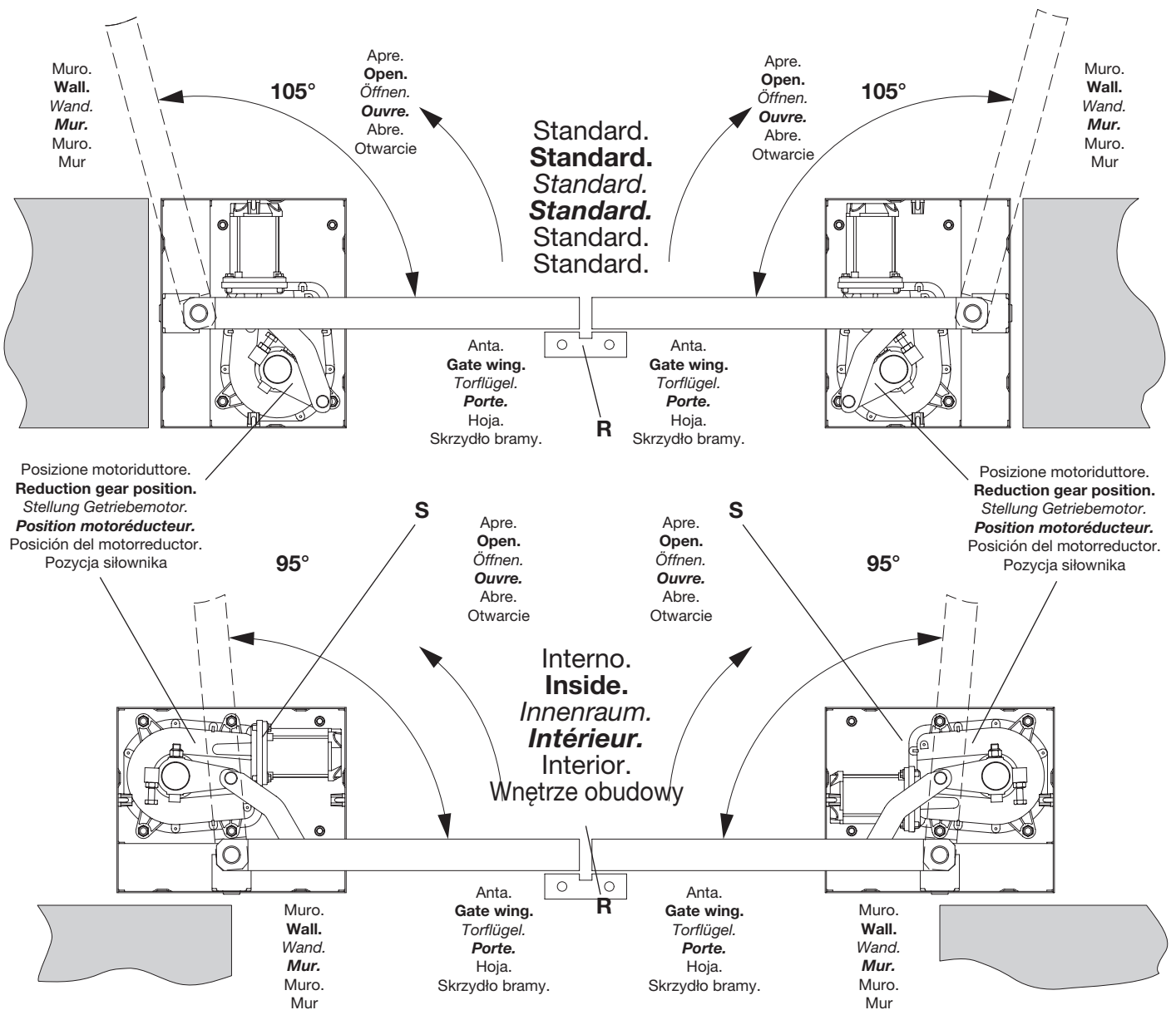

Fig.3

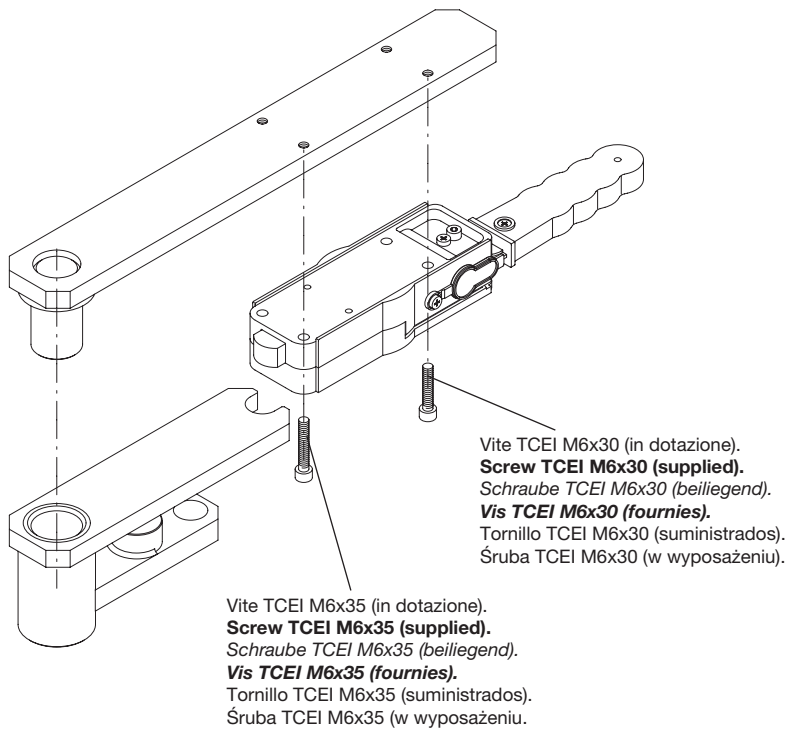

Fig.4

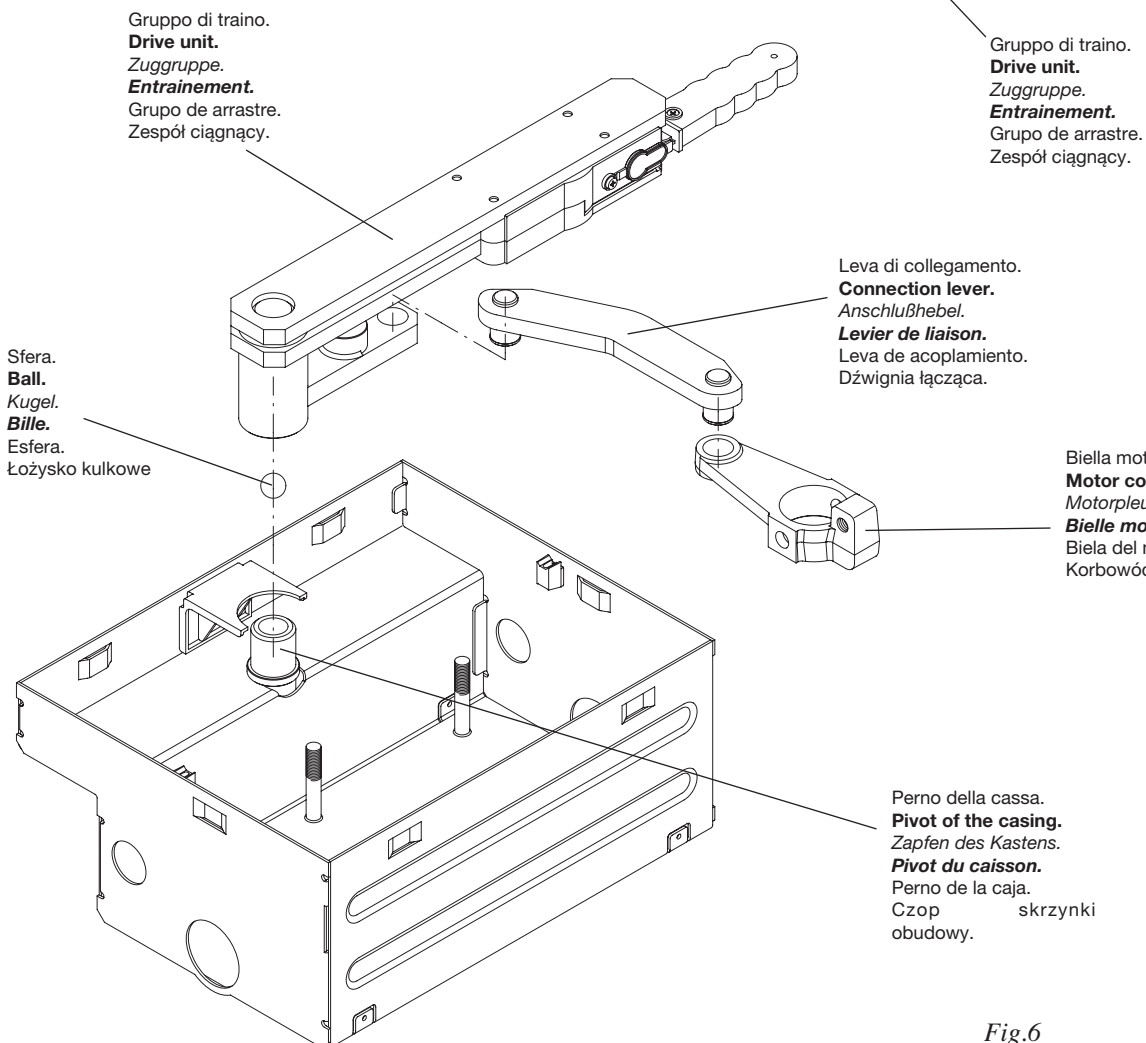
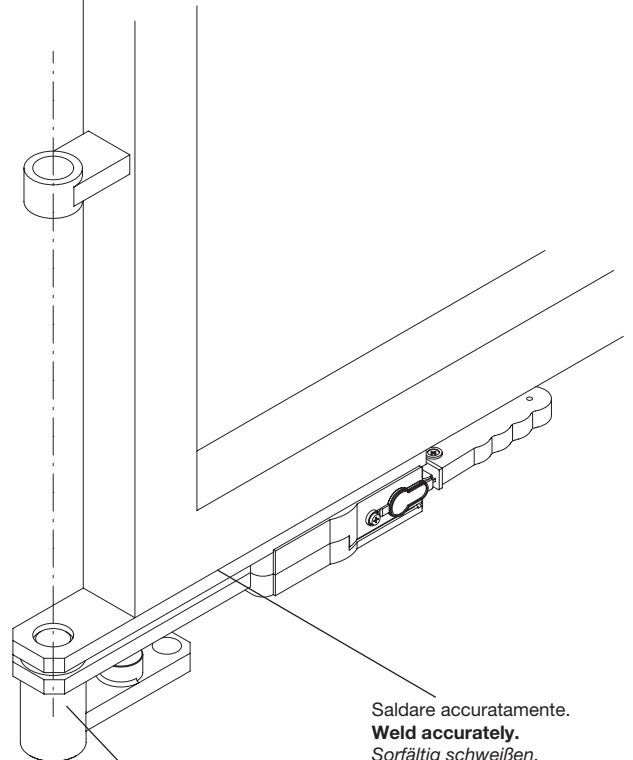

Fig.6

Fig.5

Curare l'allineamento tra la cerniera superiore ed il perno.
Align the top hinge with the pivot.
 Oberes Scharnier und Zapfen sind aufeinander auszurichten.
Soigner l'alignement entre la charnière supérieure et le pivot.
 Cuidar la alineación entre la bisagra superior y el perno.
 Dbąć o równopadłość linii pomiędzy górnym wpustem a sworzniem.



Gruppo di traino.
Drive unit.
 Zuggruppe.
Entrainement.
 Grupo de arrastre.
 Zespół ciągnący.

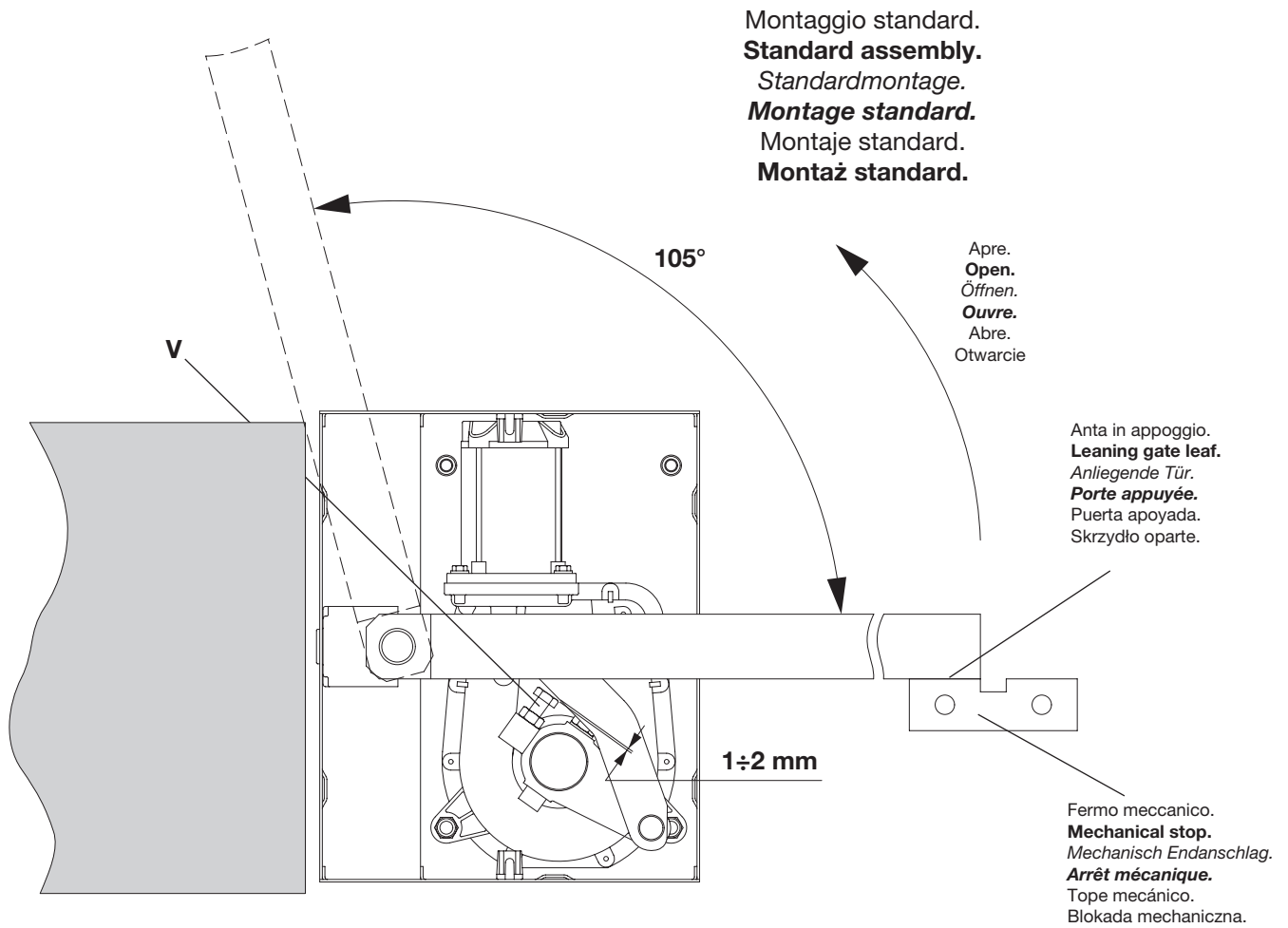

Fig.7

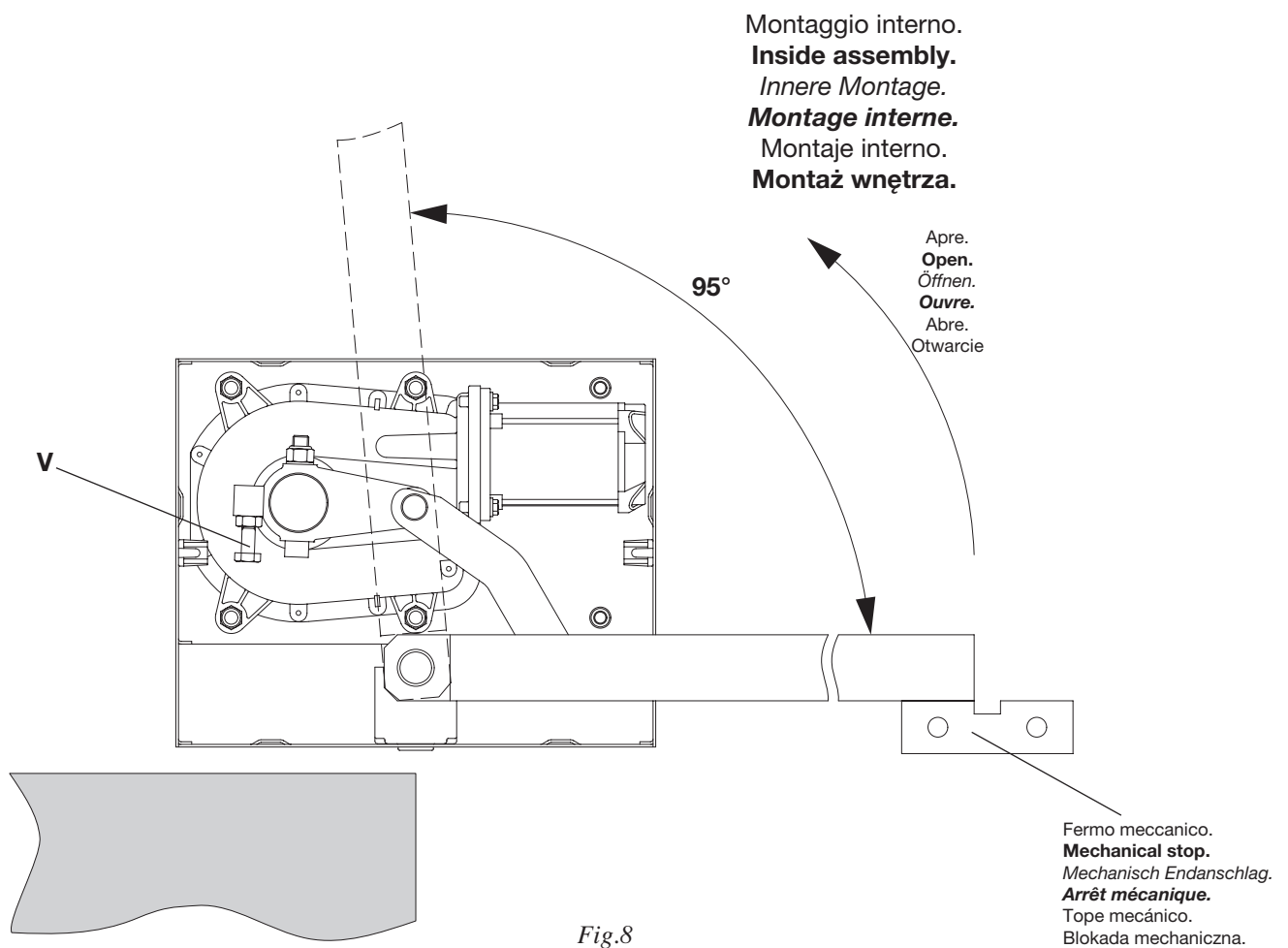
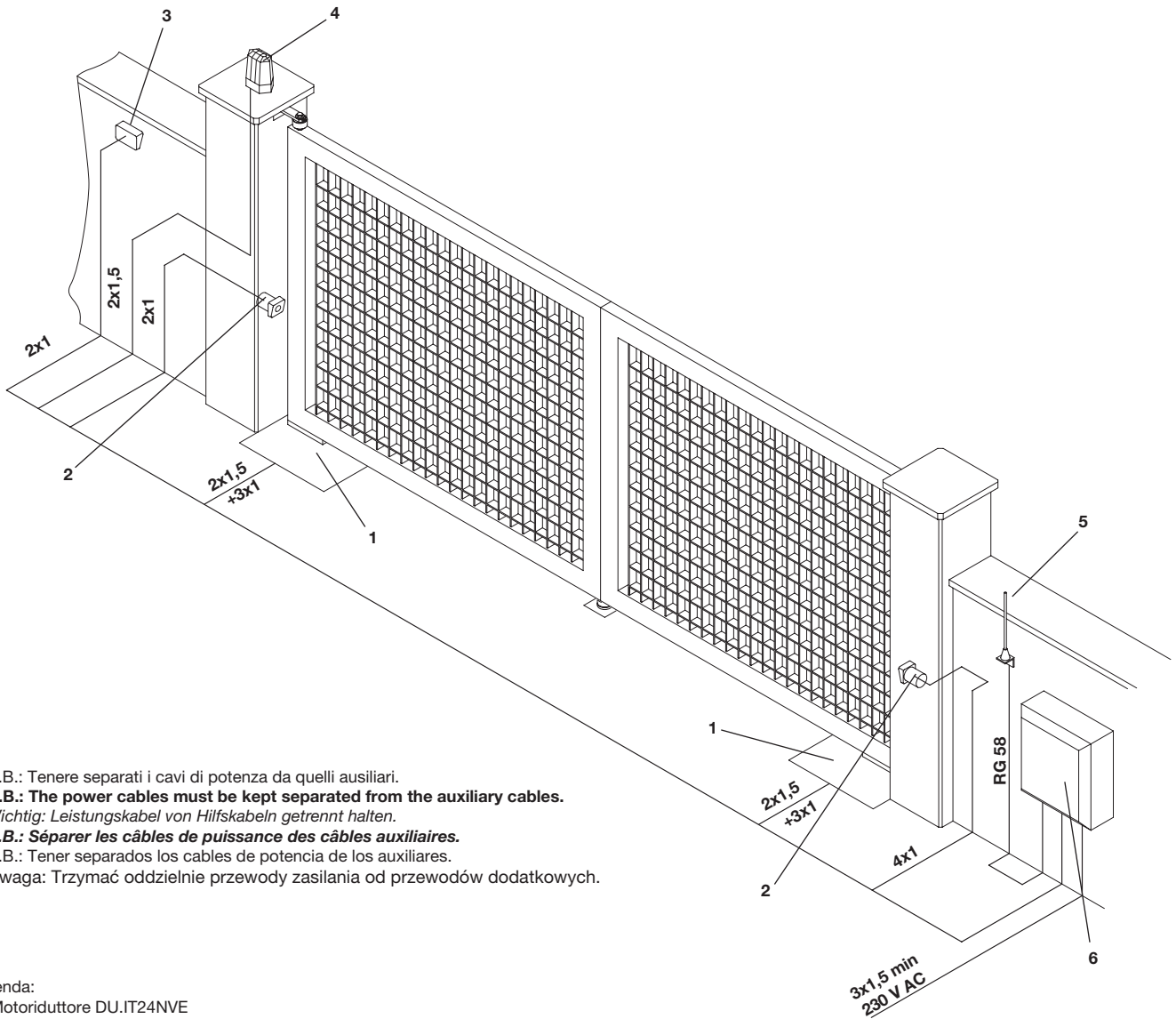

Fig.8



N.B.: Tenere separati i cavi di potenza da quelli ausiliari.

N.B.: The power cables must be kept separated from the auxiliary cables.

Wichtig: Leistungskabel von Hilfskabeln getrennt halten.

N.B.: Séparer les câbles de puissance des câbles auxiliaires.

N.B.: Tener separados los cables de potencia de los auxiliares.

Uwaga: Trzymać oddzielnie przewody zasilania od przewodów dodatkowych.

Legenda:

- 1 Motoriduttore DU.IT24NVE
- 2 Fotocellule
- 3 Selettore a chiave o tastiera digitale
- 4 Lampeggiante
- 5 Antenna
- 6 Centrale elettronica

Legenda:

- 1 Motoreducer DU.IT24NVE
- 2 Photo-electric cells
- 3 Key selector or digital keyboard
- 4 Flash-light
- 5 Antenna
- 6 Electronic gearcase

Zeichenerklärung:

- 1 Getriebemotor DU.IT24NVE
- 2 Fotozelle
- 3 Schlüssel-Selektor oder Digital-Tastatur D
- 4 Blinker
- 5 Antenne
- 6 Elektroschrank

Légende:

- 1 Moteur-réducteur DU.IT24NVE
- 2 Photocellule
- 3 Selecteur à clé ou clavier digita
- 4 Clignotant
- 5 Antenne
- 6 Centrale électronique

Leyenda:

- 1 Motorreductor DU.IT24NVE
- 2 Fotocélula
- 3 Selector a llave o teclado digital ID.PTD
- 4 Relampagueador
- 5 Antena
- 6 Central electrónica

Opis:

- 1 Siłownik DU.IT24NVE
- 2 Fotokomórki
- 3 Pilot kluczowy z przyciskami
- 4 Światło migające
- 5 Antena
- 6 Centralka elektroniczna

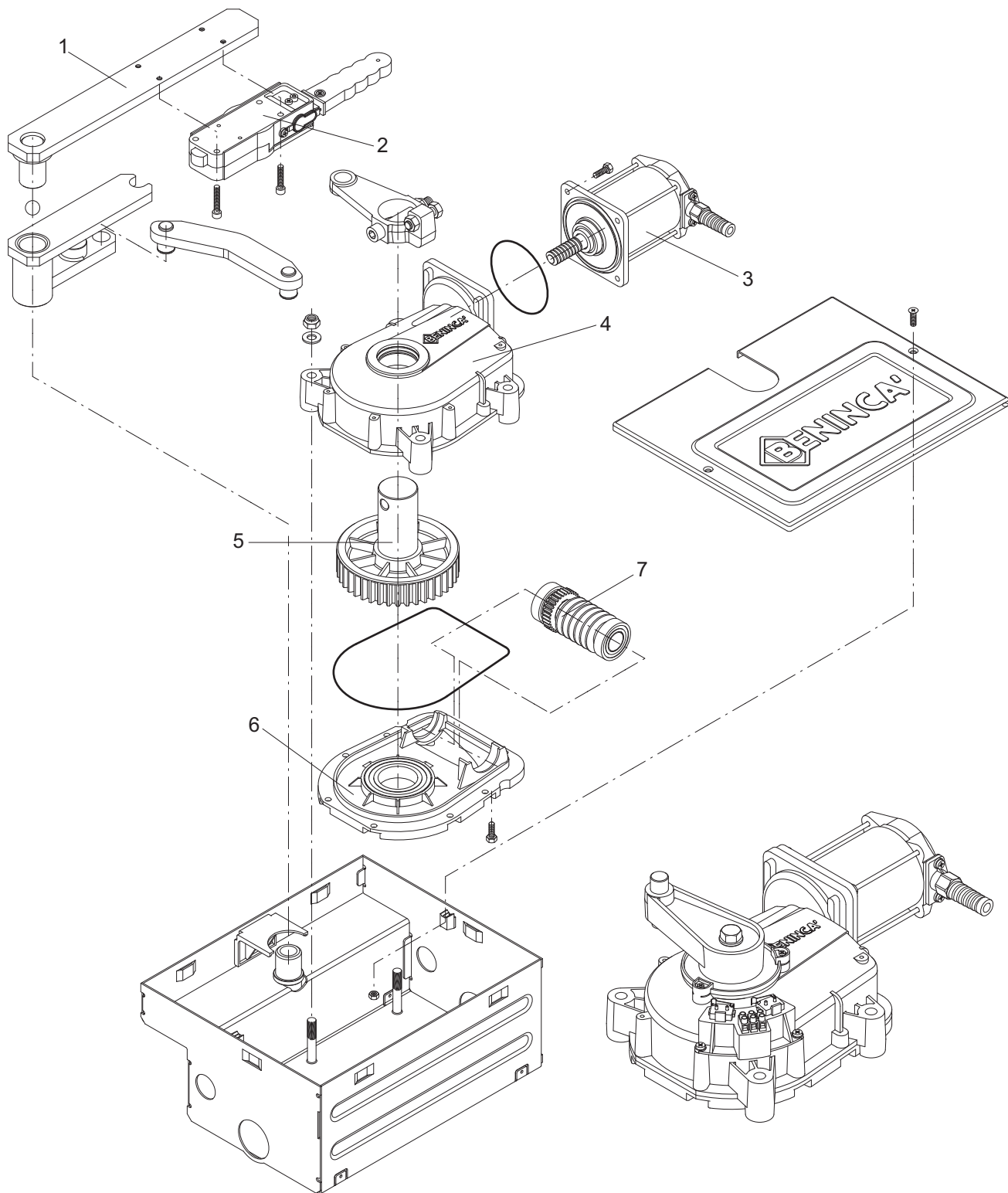

| Pos. | Denominazione - Description - Bezeichnung - Dénomination - Denominación - Określenie | | | | | | Cod. |
|------|--|---------------|-------------|------------------|------------------|------------------|---------|
| 1 | Gruppo di traino | Drive unit | Zugeinheit | Gr. d'entraînem. | Gr. de tracción | Wózek ciągnący | 9686319 |
| 2 | Sblocco | Release | Entblockung | Débloccage | Desbloqueo | Zespół odblok. | 9686282 |
| 3 | Motore | Motor | Motor | Moteur | Motor | Silnik | 9686646 |
| 4 | Carter trasmiss. | Transm. guard | Gehäuse | Carter | Caja transmis. | Karter | 9686284 |
| 5 | Ingranaggio | Gear | Zahnrad | Engrenage | Engranaje | Koło zębate | 9686322 |
| 6 | Coperchio | Cover | Deckel | Couvercle | Tapa | Karter | 9686286 |
| 7 | Vite senza fine | Worm screw | Zahnrad | Vis sans fin | Tornillo sin fin | Śruba dwustronna | 9686287 |

Warning

- Before installing the automatic system read the instructions hereunder carefully.
- It is strictly forbidden to use the product DU.IT24NVE for applications other than indicated in this instruction handbook.
- Show the user how to use the automation system.
- Give the user the part of the leaflet which contains the instructions for users.
- All Benincá products are covered by an insurance policy for any possible damages to objects and persons caused by construction faults, under condition that the entire system be marked CE and only Benincá parts be used.

General information

For an efficient operation of these automatism, the gate must have the following features:

- good stoutness and stiffness
- every wing must have one only hinge (if necessary, eliminate the others).
- all hinges must have positive clearances and permit smooth and regular manual operations.
- when wings are closed their height have to fit together.

Installation of the geared motor group

- 1 Assemble the cam "B" as per Fig. 2 and firmly tighten the screw V (tightening torque 45 Nm max).
- 2 Fit the geared motor group to the casing with 4 of the 6 nuts supplied on the casing, according to the type of assembly (see Fig. 3) and with the self-tapping screws supplied.
N.B.: Before tightening the fixing screws of the geared motor check that there is no clearance between the 4 screws and the reduction gear surface. In the negative, provide shim as required.
- 3 Pre-assemble the manual release to the gate supporting iron bar, as shown in Fig. 4.
- 4 Weld the drive unit to the gate as shown in Fig. 5.
- 5 Position the gate wing in the special niche, making sure that the ball is positioned between the pivot of the foundation casing and the drive unit. Then link the drive unit to the motor connecting rod through the special link bar (Fig. 6).

Adjustment of the mechanical limit switches

Standard assembly (ref. fig. 3-7).

- Adjust screw V so that, when the gate leaf leans against the mechanical stop, about 1÷2 mm space is left.
- The opening limit switch is fixed and averts that the gates overcomes 105°. For smaller openings use a mechanical stop on the ground or the electromechanical group DU.FCN.

Inside assembly (ref. fig. 3-8).

- The closing limit switch is composed of either the mechanical stop on the ground or the electro-mechanical group DU.FCN.
- For the opening limit switch, regulate the screw V (95° max.). For greater openings use the group DU.IT180N.

Connections

For connections to the electronic gear case, please refer to instructions relative to the electronic gear case itself.

Encoder Connection:

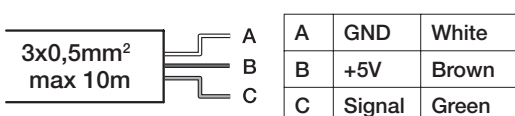

DU.IT24NVE

User's handbook

Safety rules

- Do not stand in the movement area of the gate.
- Do not let children play with controls and near the gate.
- Should operating faults occur, do not attempt to repair the fault but call a qualified technician.

Manual and emergency operation

Should a power failure or a break-down occur, the gate can be manually opened and closed as follows (refer to figure):

- 1 Remove the protection cap "T" of the gate lock which is pressure-inserted.
- 2 Insert the key "C" and turn it until rotation is no longer smooth.
- 3 Rotate the lever "L" in either direction until activation of the limit switch.

Now the gate can be manually operated.

To reset the automatic operation of the gate, move the lever "L" back to the original position, turn and extract the special key "CE" and replace the cap "T". The normal operation of the gate will be reset with the first movement of the gate.

Maintenance

- Every month check the good operation of the emergency manual release.
- It is mandatory not to carry out extraordinary maintenance or repairs as accidents may be caused. These operations must be carried out by qualified personnel only.
- The operator is maintenance free but it is necessary to check periodically if the safety devices and the other components of the automation system work properly. Wear and tear of some components could cause dangers.

Waste disposal

If the product must be dismantled, it must be disposed according to regulations in force regarding the differentiated waste disposal and the recycling of components (metals, plastics, electric cables, etc.). For this operation it is advisable to call your installer or a specialised company.

Warning

All Benincá products are covered by insurance policy for any possible damages to objects and persons caused by construction faults under condition that the entire system be marked CE and only Benincá parts be used.

Position for the automatic operation.

